

EPIC HF

EPIC HF Indexing Chuck Rotary Transfer Machine

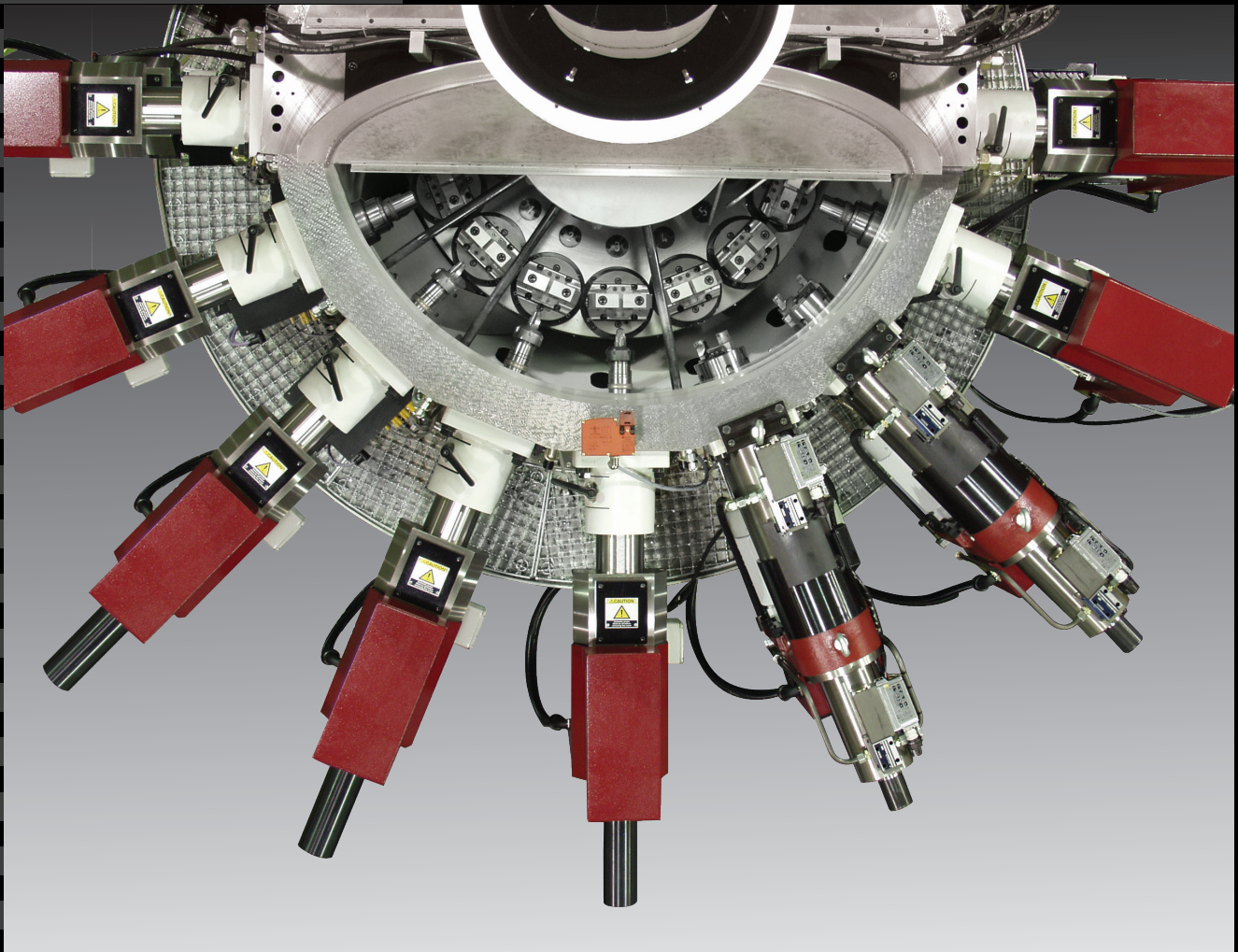

PROFITABILITY

FANUC 30i-MODEL B CONTROL

The 30i-B is an advanced CNC for multi-axes, multi-path machine tools. Due to the high number of controlled axes and paths, various machining processes can be executed at the same time. Advanced software algorithms analyze part geometries and machine capabilities and adjust trajectories and feedrates to provide the smoothest tool paths for the highest processing speed at the specified precision. The CNC and drive system executes at a nanometer resolution all the way down to the 16-million count encoders for the maximum precision and the smoothest contoured surface finish quality.

The Ethernet interface integrates the CNC into a network for high-speed part program transfers and the collection of process related data. Reliable hardware with clear diagnostics provides a stable platform for maximum machine availability.

Operators with previous FANUC and/or CNC programming experience can use their existing skills as they learn new techniques, to program parts on their Hydromat machine.

State-of-the-Art Hardware

High-speed and high reliability is achieved by state-of-the-art hardware, including ultra-high-speed processors, high-speed CNC internal bus and optical fiber cables used for high-speed data transfer.

High-speed, high accuracy machining is realized by using not only a CNC that controls the machine with nanometer resolution but also servos and drive systems that accurately position the machine. The 30i-B can be integrated with customer network systems.

EPIC HF

EPIC HF Indexing Chuck Rotary Transfer

The EPIC HF Indexing Chuck machine combines precision chucks with the indexing accuracy and reliability of the Hirth ring.

Available in 12 or 16 station models, the Indexing Chuck machine is fully integrated into the Hydromat program, so the same modular components used with Hydromat's popular EPIC R/T models are compatible with the EPIC HF Indexing Chuck models.

This system is ideal for the mid to high-volume, precision production of irregular-shaped castings or forgings and is designed with the flexibility to easily accommodate families of parts.

The EPIC HF Indexing Chuck machine utilizes hydraulically-actuated, self-centering two or three-jaw chucks, or custom clamp fixtures, to provide the highest accuracy and part clamping

rigidity. This type chuck indexing provides precise part positioning for complex multi-axis machining that requires one chucking to maintain overall part quality and statistical capability.

The indexing chucks are positioned on the rotary table in a satellite arrangement and are indexed hydraulically. Indexing of the satellite chucks is free programmable, CNC controlled, and can be arranged so that no cycle time is lost. Variable clamping pressure can be provided to critical chucks at certain stations for ideal gripping performance without damaging or distorting the finished part.

A large group of irregular-shaped components, cast or forged, can be loaded by semi-automatic or fully-automatic pick-and-place systems, or bowl feeding, depending upon the specific part requirements. Loading and unloading takes place on the same station, and typically falls well within the cycle time. Bar stock also can be fed to the machine using a fully automatic bar feeder and cutoff saw.



ACCURACY

The EPIC HF 12 & 16 station Indexing Chuck machines have the rigidity to handle all components within the capacity range of the machine: 4" cube capacity on the 12 station and 3" cube capacity on the 16 station.

A precision ground Hirth ring assures that the table accuracy and reliability from station-to-station repeats within .0002".

The EPIC HF machines possess all of the general characteristics of the more conventional Hydromat machines and maintains the integrity, reliability and flexibility of its predecessors. Applying CNC technology to the manufacture of precision parts is generally accepted as a premium that one must pay for

the advantages over conventional actuation systems.

When it comes to improving profitability, the EPIC HF Machines with full CNC programmability are able to enhance ROI by reducing changeover times by 300 - 400% (1-3 hours versus 7-9 hours). This reduced changeover time increases overall machine productivity by over 15%: based on a two-shift operation and 2 changeovers a week. The increased productivity equates to payback or ROI for the Hydromat EPIC HF Machines being up to 20%* faster due to reduced changeover and greater productivity.

*(based on hypothetical 6.0 second cycle time and 30 cent part selling price)



Specifications

Model	Blank	Round	Length	Hor. Station	Vert Station	Index Time	Weight LBS	Machine Power	Size Unit
12 Station	4" cube	1 3/4"	8"	12	6	1.2	18,500	53HP (Avg.)	20/80 26/80 35/60
16 Station	3" cube	1 3/4"	6"	16	8	1.0	20,000	66HP (Avg.)	36/100 46/120 50/100

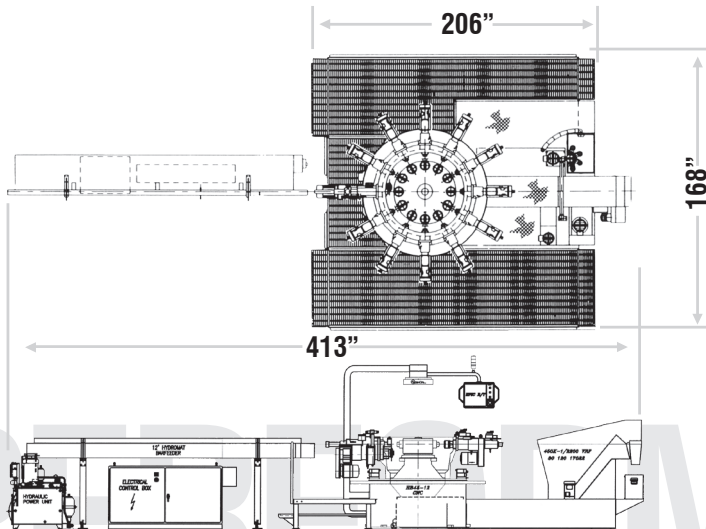



EPIC HF

The Series 30i-MODEL B by FANUC was designed for today's most complex, high-performance machines with a large number of axes, multiple part program paths and high-speed auxiliary machine functions. The Series 30i-MODEL B CNC is ideal for your next Hydromat rotary transfer machine, whether it is running a simple application, or the most complex part profile, with a multi-axis application. The PC functions with the Windows® OS system. There is consistent support at shop floor with the FANUC iHMI.

High Reliability and Easy Maintainability

Highly reliable hardware allows stable operation in a harsh factory environment. Various types of enhanced diagnosis functions improve maintainability so that the cause of trouble can be identified quickly.

The use of ultra-high-speed serial communications reduces wiring. Powerful PMC allows flexibility of machine design, and built-in safety function helps to confirm safety regulation easily.

FANUC Operational Features

- Enhanced functionality and superior performance extends the potential of machine capabilities into the future
- CNC enhancements can be adopted over time, either by learning on the CNC or by using FANUC's realistic and efficient NCGuide CNC simulator
- Custom Macro extends the standard programming language to include the features of an easy-to-use, yet powerful computer programming language
- Familiar folder tree-view is similar to that used on PCs, making it easy to visualize the structure
- Simple menu-driven conversational programming screens eliminate the tedium and error-prone process of generating the same multiple blocks of G-code
- MANUAL GUIDE i is supported by NCGuide and NCGuidePro

FANUC Control Benefits

- Available on the World's Best-In-Class Machine Tools
- Ultimate Resolution And Precision for Quality Machining
- High-Speed, High Precision and High Quality Machining and Reduced Cycle Times
- Simple Operation For Maximum Productivity
- Connectivity For Today's High-Tech Manufacturing
- High Reliability And Easy Maintenance
- High-Speed, High Precision and Smooth Simultaneous Multi-Spindle Machining
- Powerful Simulation Tools
- State-of-the-Art Hardware
- Customer-Specific Solutions



11600 Adie Road • St. Louis, MO 63043
314.432.4644 • www.hydromat.com

FANUC 30i-B