

EPIC HF

EPIC HF 32/45-16 Rotary Transfer Machine

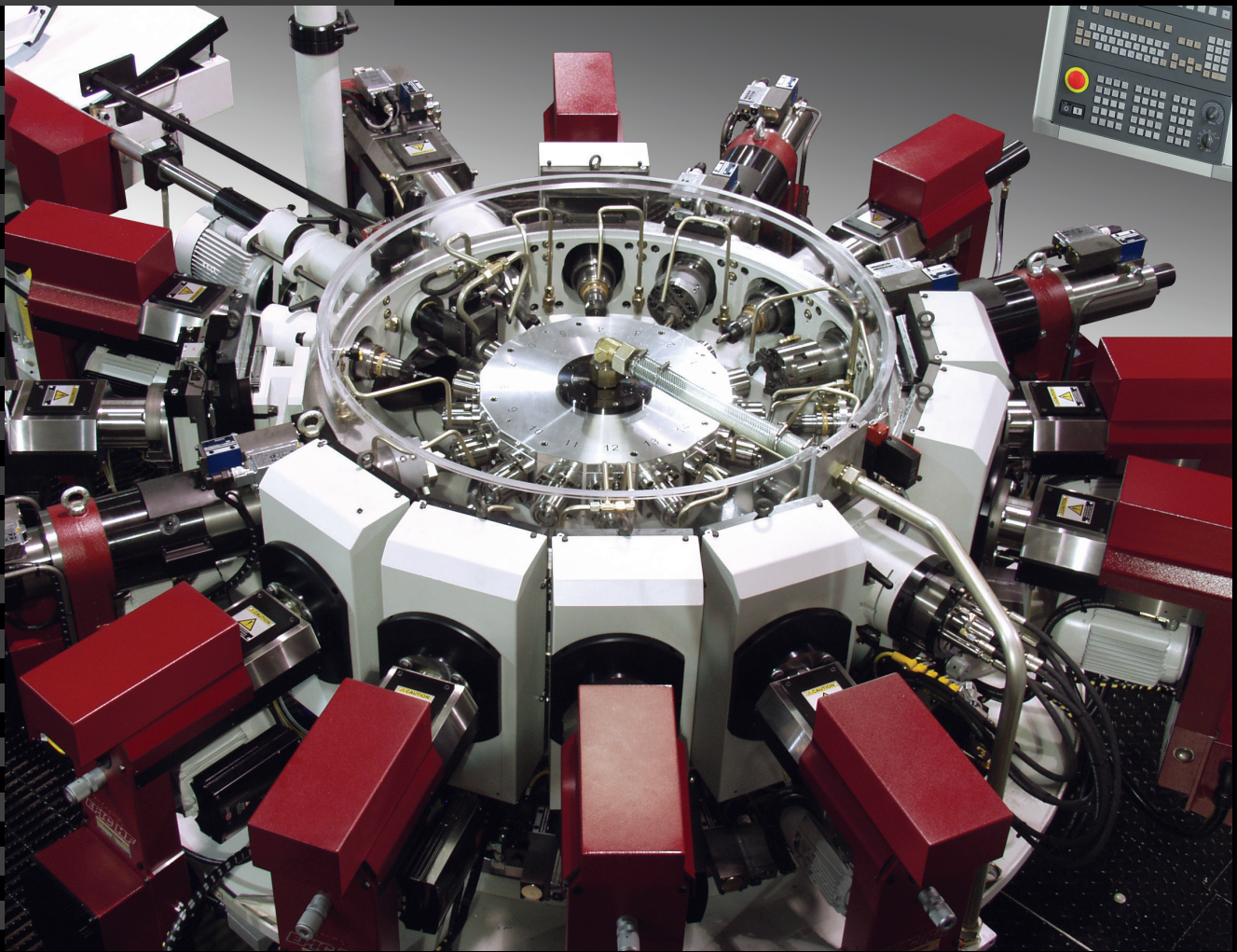

HYDROMAT[®]

VERSATILITY

FANUC 30i-MODEL B CONTROL

The 30i-B is an advanced CNC for multi-axes, multi-path machine tools. Due to the high number of controlled axes and paths, various machining processes can be executed at the same time. Advanced software algorithms analyze part geometries and machine capabilities and adjust trajectories and feedrates to provide the smoothest tool paths for the highest processing speed at the specified precision. The CNC and drive system executes at a nanometer resolution all the way down to the 16-million count encoders for the maximum precision and the smoothest contoured surface finish quality.

The Ethernet interface integrates the CNC into a network for high-speed part program transfers and the collection of process related data. Reliable hardware with clear diagnostics provides a stable platform for maximum machine availability.

Operators with previous FANUC and/or CNC programming experience can use their existing skills as they learn new techniques, to program parts on their Hydromat machine.

State-of-the-Art Hardware

High-speed and high reliability is achieved by state-of-the-art hardware, including ultra-high-speed processors, high-speed CNC internal bus and optical fiber cables used for high-speed data transfer.

High-speed, high accuracy machining is realized by using not only a CNC that controls the machine with nanometer resolution but also servos and drive systems that accurately position the machine. The 30i-B can be integrated with customer network systems.

EPIC HF

EPIC HF 32/45-16 Rotary Transfer Machine

FANUC Nano CNC for High Speed, High-Accuracy Machining

The Hydromat EPIC HF 32/45-16 is a FANUC control equipped rotary transfer machine for precision metal cutting of stock sizes that range up to 1.75 inch round, 1.5 inch hex, 1.25 inch square, and a part length to 6 inches. It may be equipped with collets or chucks for precision metal removal. This exceptional design is a modular system consisting of horizontal and vertical toolspindles

rigidly mounted around a precision cast base. It utilizes up to 16 horizontal toolspindles and has the capacity of 8 vertical toolspindles. That's up to 24 tools in the cut at once. This design provides tremendous versatility and flexibility in a turnkey machining system. It has the rigidity to handle all components and all material types within its work envelope.

The wide variety of EPIC style rotary transfer machines offered by Hydromat give production machining professionals the right tool for the right job. The Hydromat system is the solution for the elimination of

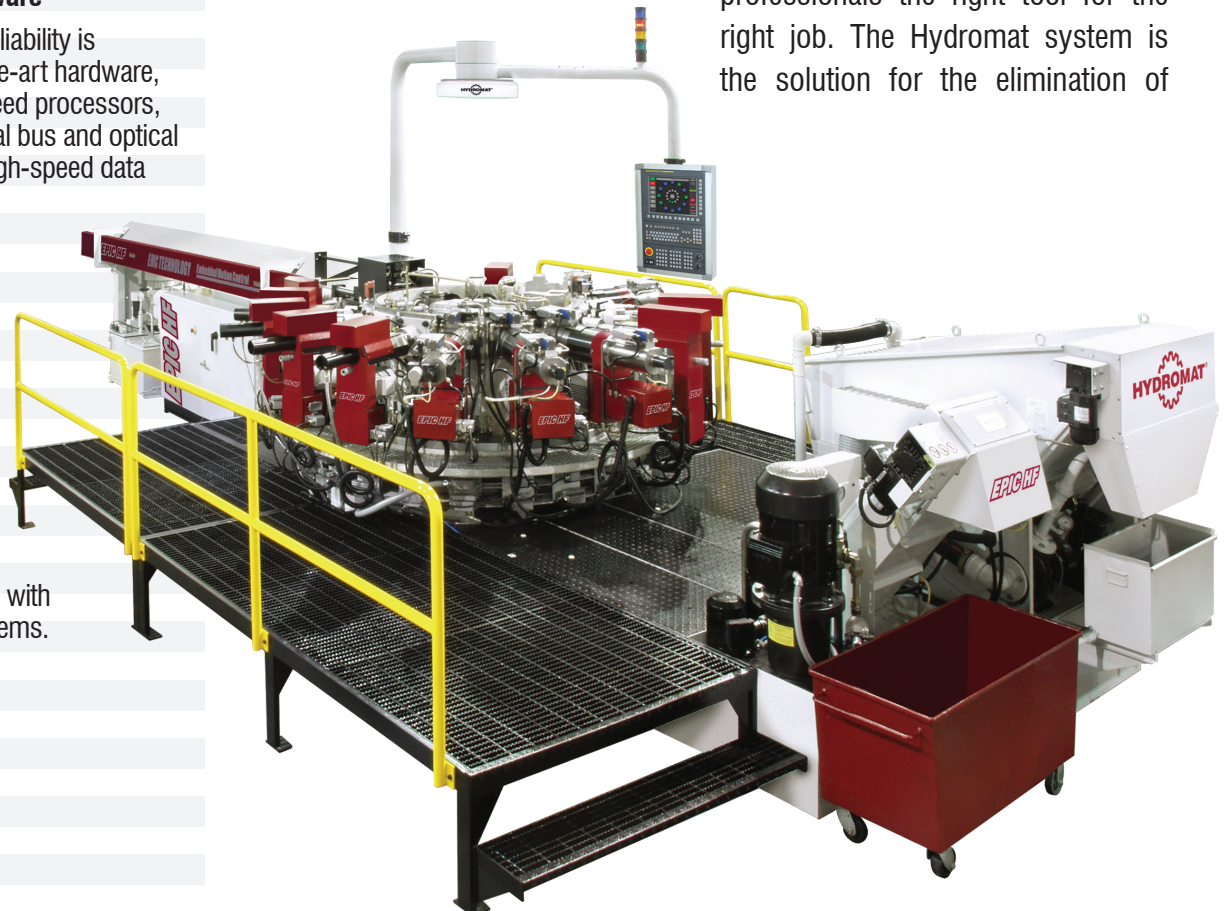



secondary operations by producing parts complete from bar stock, castings, forgings or cold formed blanks. The Hydromat machining platform reduces work in progress and additional cost reduction is realized due to extremely short remnants that translate to significant material saving. Increased productivity is partially due to modular toolspindle system with quick-change presettable tool heads for easy changeovers.

A precision ground Hirth ring assures that the table accuracy and reliability

from station-to-station repeats within .0002".

Typical components ideally suited for machining on Hydromats include: automotive ABS and brake systems, fuel, electrical, engine and steering components, plumbing, hydraulic fittings, HVAC valve castings, faucet bodies, gas valves and connectors, hardware power tool and appliance housings, electrical wire connectors and switch bodies, defense and aerospace fuse bodies, and instrument housings.

Specifications

Max Stock Size				Hor. Station	Vert. Station	Index Time	Weight LBS	Machine Power	Size Unit
Rnd	Hex	Sq	Length						
1 3/4"	1 1/2"	1 1/4"	6"	16	8	0.9	16,500	60HP (Avg.)	EPIC 26/80 EPIC 36/100 EPIC 46/120 EPIC 50/100

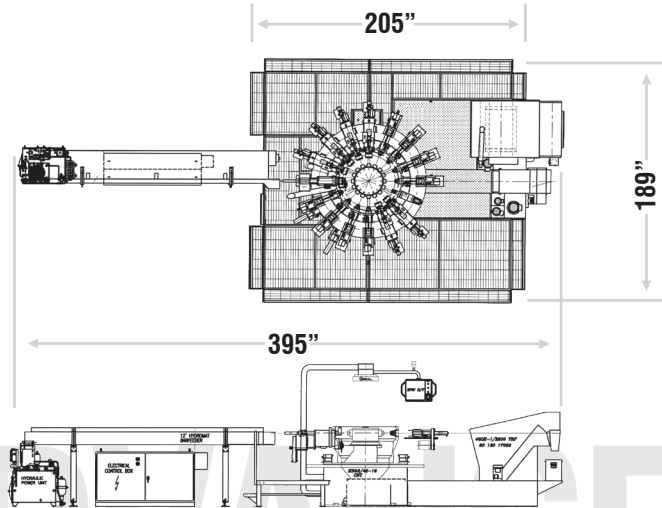

ADVANCEMENTS

The Series 30i-MODEL B by FANUC was designed for today's most complex, high-performance machines with a large number of axes, multiple part program paths and high-speed auxiliary machine functions. The Series 30i-MODEL B CNC is ideal for your next Hydromat rotary transfer machine, whether it is running a simple application, or the most complex part profile, with a multi-axis application. The PC functions with the Windows® OS system. There is consistent support at shop floor with the FANUC iHMI.

High Reliability and Easy Maintainability

Highly reliable hardware allows stable operation in a harsh factory environment. Various types of enhanced diagnosis functions improve maintainability so that the cause of trouble can be identified quickly.

The use of ultra-high-speed serial communications reduces wiring. Powerful PMC allows flexibility of machine design, and built-in safety function helps to confirm safety regulation easily.



EPIC HF

FANUC Operational Features

- Enhanced functionality and superior performance extends the potential of machine capabilities into the future
- CNC enhancements can be adopted over time, either by learning on the CNC or by using FANUC's realistic and efficient NCGuide CNC simulator
- Custom Macro extends the standard programming language to include the features of an easy-to-use, yet powerful computer programming language
- Familiar folder tree-view is similar to that used on PCs, making it easy to visualize the structure
- Simple menu-driven conversational programming screens eliminate the tedium and error-prone process of generating the same multiple blocks of G-code
- MANUAL GUIDE i is supported by NCGuide and NCGuidePro

FANUC Control Benefits

- Available on the World's Best-In-Class Machine Tools
- Ultimate Resolution And Precision for Quality Machining
- High-Speed, High Precision and High Quality Machining and Reduced Cycle Times
- Simple Operation For Maximum Productivity
- Connectivity For Today's High-Tech Manufacturing
- High Reliability And Easy Maintenance
- High-Speed, High Precision and Smooth Simultaneous Multi-Spindle Machining
- Powerful Simulation Tools
- State-of-the-Art Hardware
- Customer-Specific Solutions



11600 Adie Road • St. Louis, MO 63043
314.432.4644 • www.hydromat.com

FANUC 30i-B